

PLIDCO® HYDRAULIC POWER+GRIP CONNECTOR

Connect With the Power of PLIDCO®

The PLIDCO® Hydraulic Power+Grip, like its partner the Bolted Power+Grip, is designed for safe, easy and reliable replacement of underwater risers, connection of off-shore systems, pipeline spool piece repair, pipeline reroutes and abandonments, structural repairs and valve or tee installations. The hydraulic model features grip and seal actuation via hydraulic pressure, dramatically reducing installation time. The diver friendly PLIDCO® Hydraulic Power+Grip has a double row of seals with a test port to prove seal integrity before repressurizing the line. The PLIDCO® Hydraulic Power+Grip accepts additional external loading and offers a generous end gap adjustment as well as oversized and undersized pipe tolerances. The integrated grip acts independently of the seal actuation and is designed for powerful structural attachment to the pipe. It is in compliance with ASME Section VIII Div. 2. NACE options are available upon request. This model is stocked in sizes 14", 16", 20", 24"; ASME/ANSI Class 600# and 900#. Other sizes/classes available upon request.

Standard Body Material:

- SA-A105

Standard Grip Material:

- AISI 4140

Standard Seals:

- Viton

Standard Coating:

- Everslik 1201
- Everlube 6110

Options:

- NACE MR0175/ISO 15156 compliant material

Hydraulic Requirements:

- Minimum 4,000psi
- Minimum 30 gallon reservoir

HYDRAULIC FEATURES

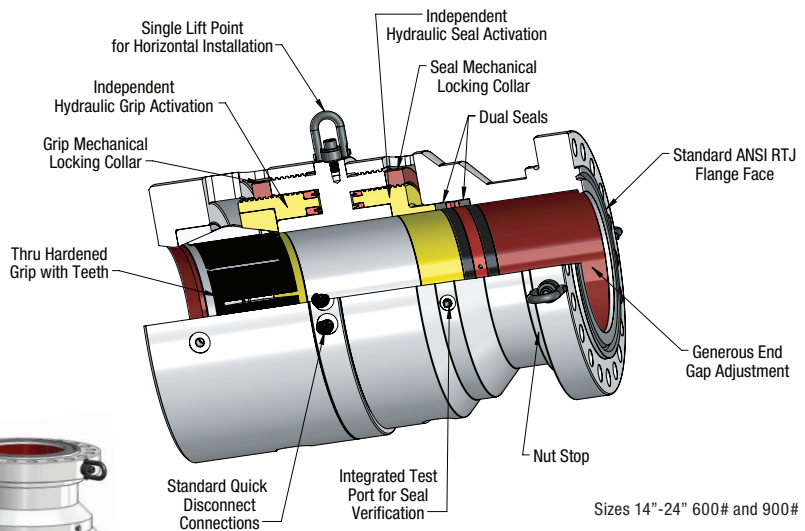

HYDRAULIC GRIP & SEAL

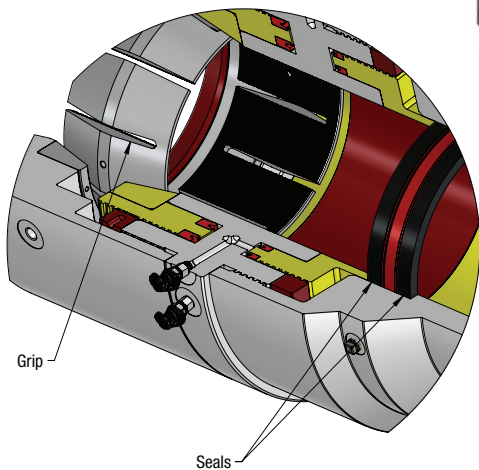

HYDRAULIC SECTION VIEW

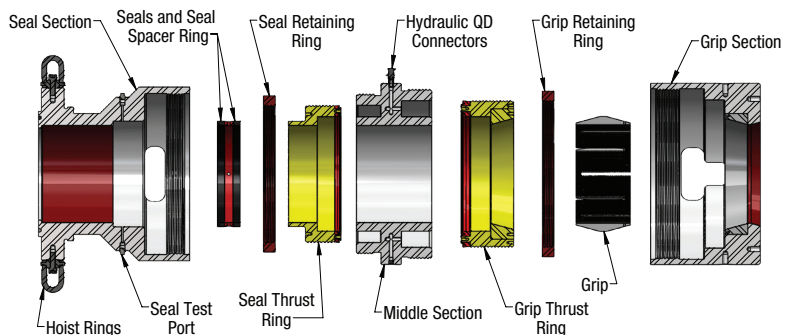

PIP081 02/23

Trust the Original.
Trust PLIDCO®

THE PIPE LINE DEVELOPMENT COMPANY

11792 Alameda Drive • Strongsville, Ohio 44149 • USA
+1 440-871-5700 • Fax +1 440-871-9577
pipeline@plidco.com • www.plidco.com

"Working together to make
hazardous piping safer"

PLIDCO® POWER+GRIP CONNECTOR

Connect With the Power of PLIDCO®

The PLIDCO® Power+Grip is designed for safe, easy and reliable replacement of underwater risers, connection of off-shore systems, pipeline spool piece repair, pipeline reroutes and abandonments, structural repairs and valve or tee installations. The fitting requires no welding and there is minimal pipe end preparation for installation. The diver friendly PLIDCO® Power+Grip has a double row of packing with a test port between the rows to prove seal integrity before pressurizing the line. The fully mechanical PLIDCO® Power+Grip accepts external loading and offers a generous end gap adjustment as well as oversized and undersized pipe tolerance. The integrated grips act independently of the seal actuation and are designed for powerful structural attachment to the pipe. The fitting is able to be removed, reconditioned by PLIDCO® and put back in customer stock for future use. It is in compliance with ASME Section VIII Div. 1 and NACE options are available upon request. This model is available in sizes 2"-12"; ASME/ANSI Class 600# and 900#. See Hydraulic Power+Grip for larger sizes.

Standard Body Material:

- SA-A105

Standard Grip Material:

- AISI 8620

Standard Seals:

- Viton

Standard Coating:

- Everslik 1201

- Everlube 6110

Options:

- NACE MR0175/ISO 15156 compliant material

- Anodes for corrosion protection



POWER+GRIP USES

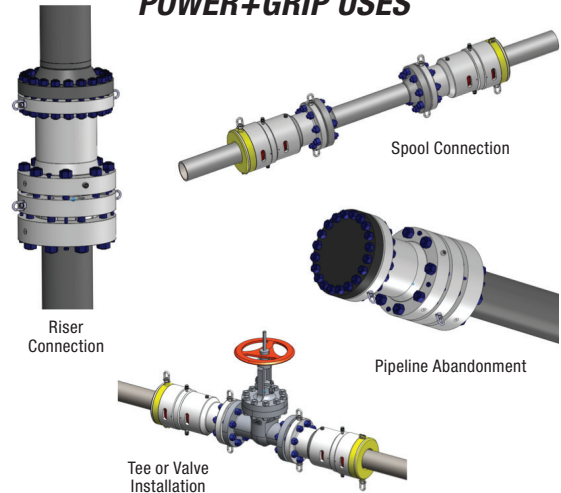

BOLTED FEATURES

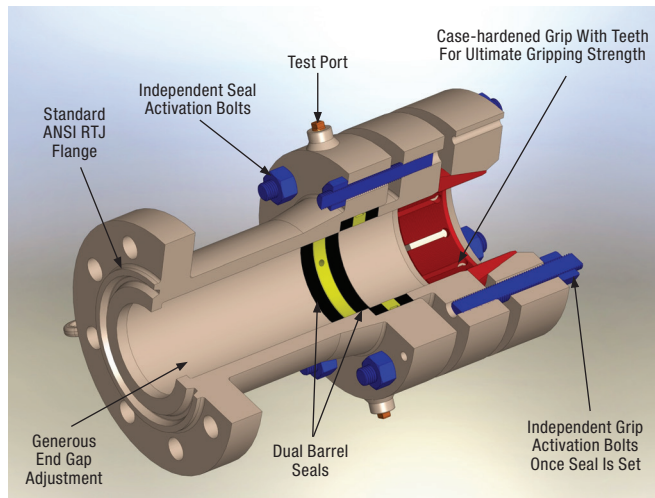

BOLTED SECTION VIEW

